

TYER'S N° 12A2 KEY TOKEN INSTRUMENT

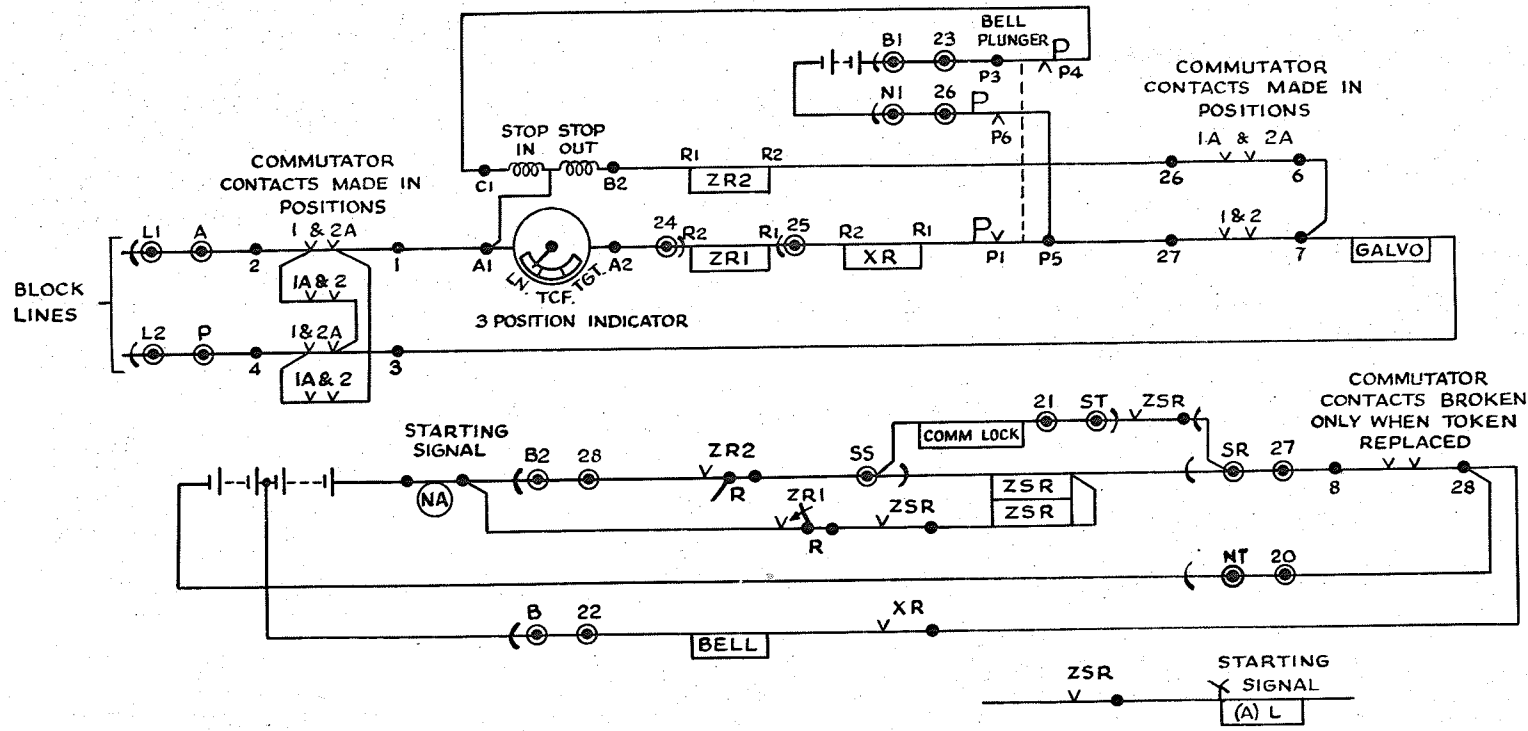

- ZR1 - 2 POSITION POLAR BIAS RELAY (6.5 Ω)
- ZR2 - 3 POSITION POLAR BIAS RELAY (50 Ω)
- XR - NEUTRAL RELAY (25 + 25 Ω)
- ZSR - DOUBLE WOUND D.C. NEUTRAL RELAY (500/500 Ω)

COMMUTATOR SEQUENCE TO WITHDRAW TOKEN 1, 1A, 2 OR 2A, 1.

—⤵ DENOTES LIMIT OF WIRING WITHIN INSTRUMENT.

FIG. 1

CANCELLED

TYER'S KEY-TOKEN INSTRUMENT
THREE POSITION INDICATOR

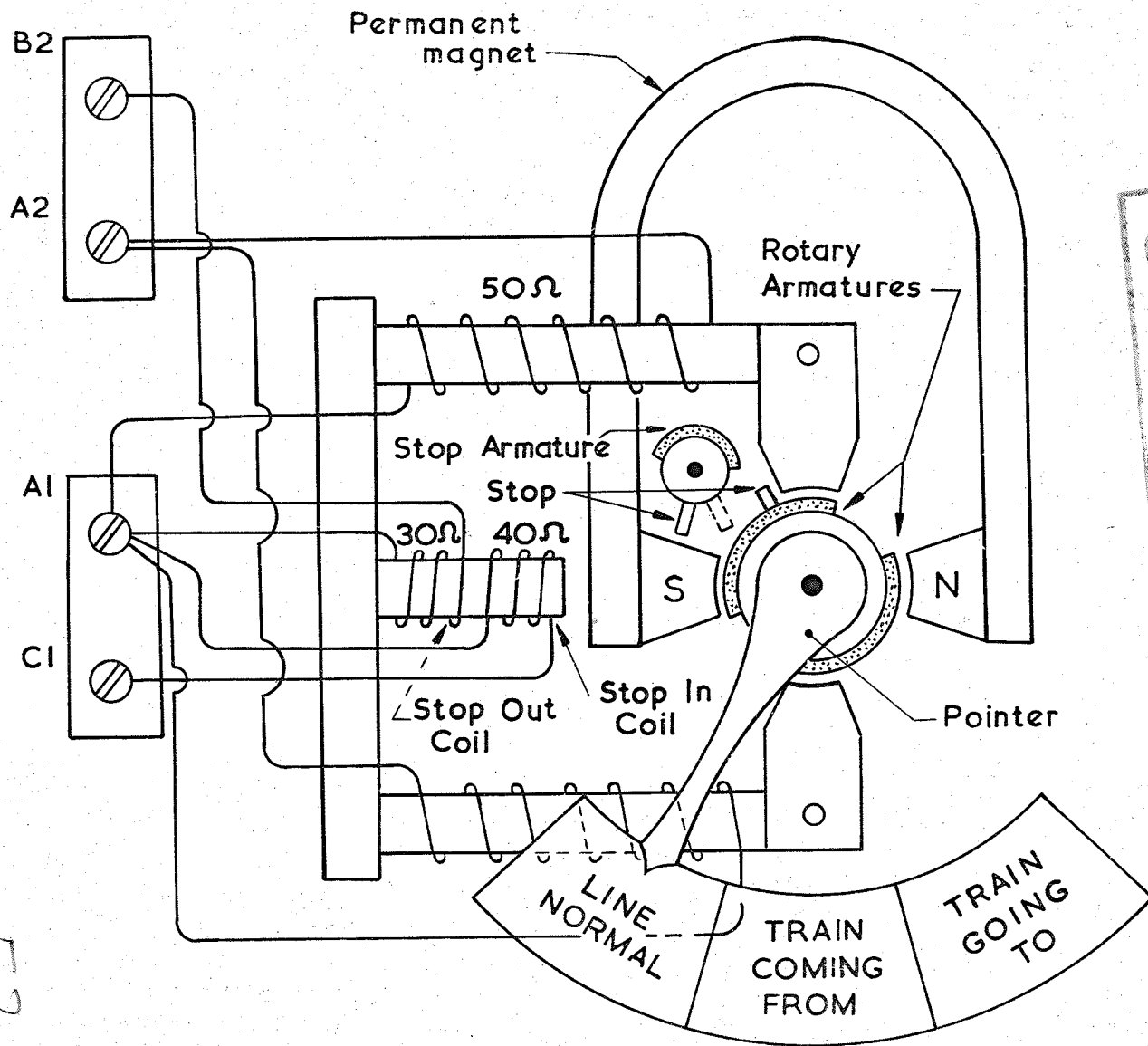

CANCELLED

F2

FIG. 2

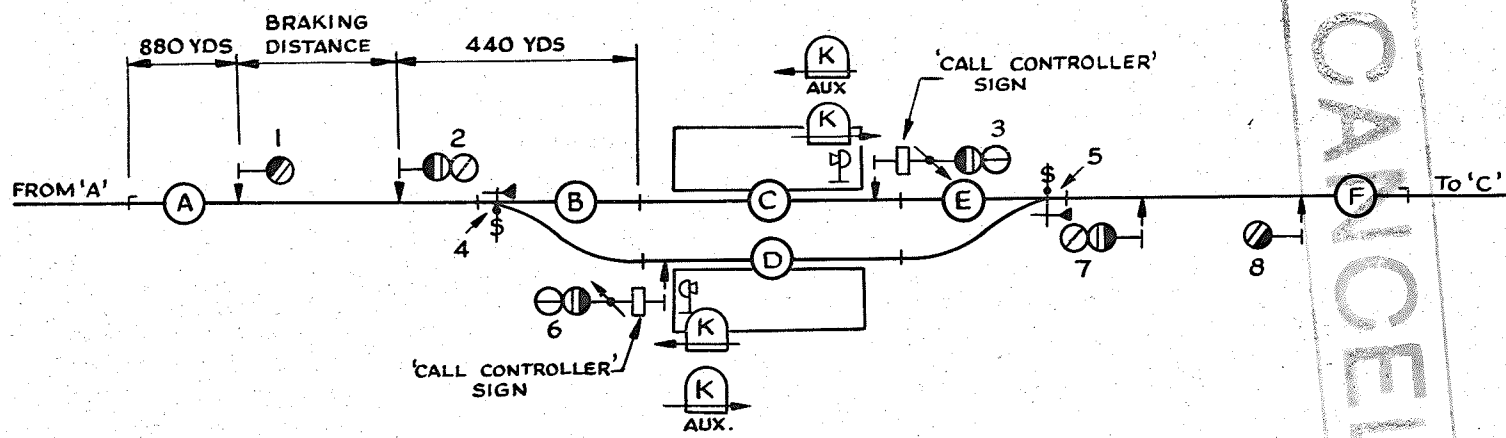

CANCELLED

PROPOSED WORKING OF SINGLE LINES
BY KEY TOKEN 'NO SIGNALMAN' INSTRUMENTS

FIG. 3

FW

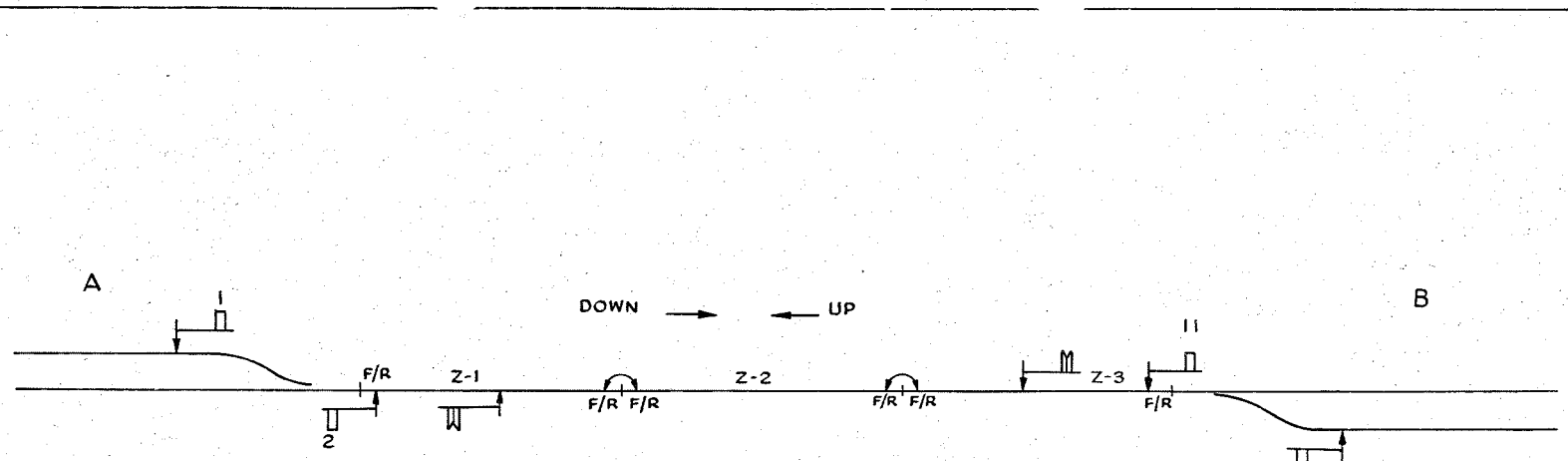

3 DIRECTION LEVER (FOR UP TRAINS)

10 DIRECTION LEVER (FOR DOWN TRAINS)

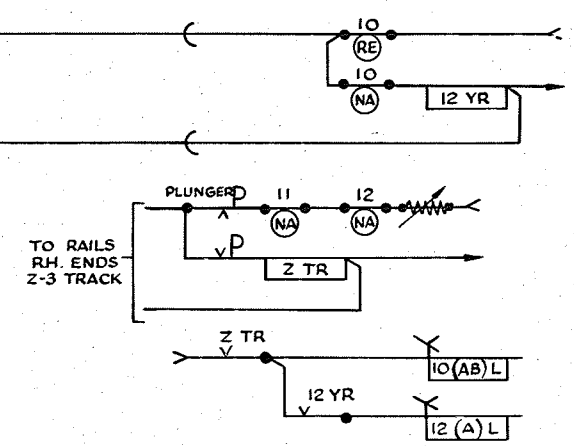
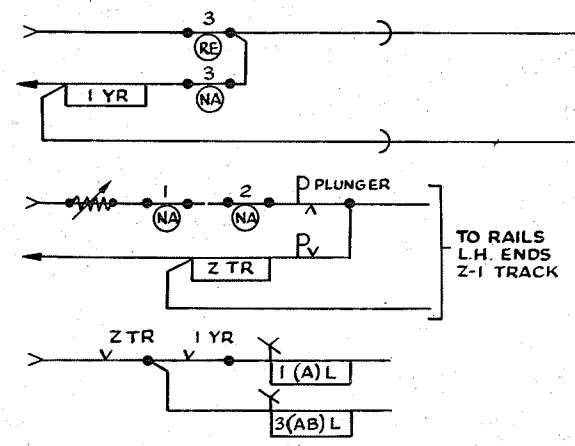

CANCELLED

SINGLE LINE WORKING USING TRANSIENT TRACK CIRCUIT
AND DIRECTION LEVER - SIMPLIFIED CIRCUIT

FIG. 4

FA

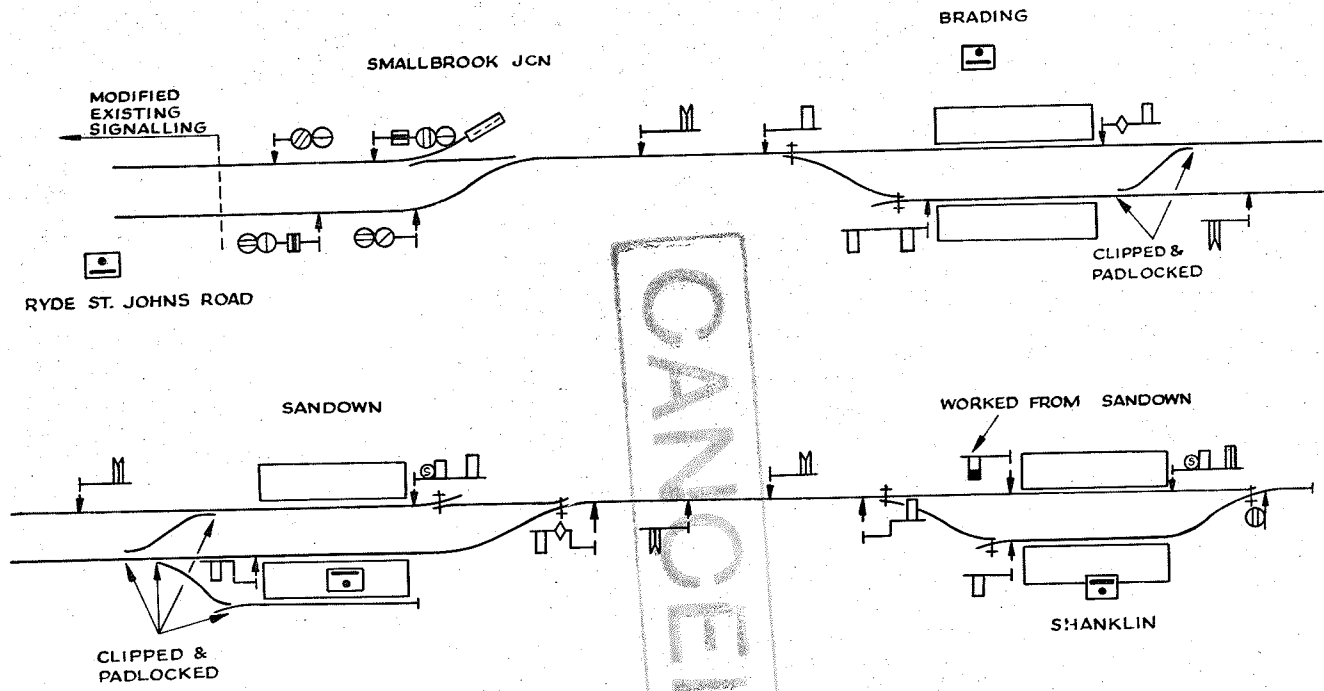

RYDE ST. JOHNS ROAD TO SHANKLIN
SIGNALLING FOR ELECTRIFICATION

FIG. 5

CANCELLED

FS

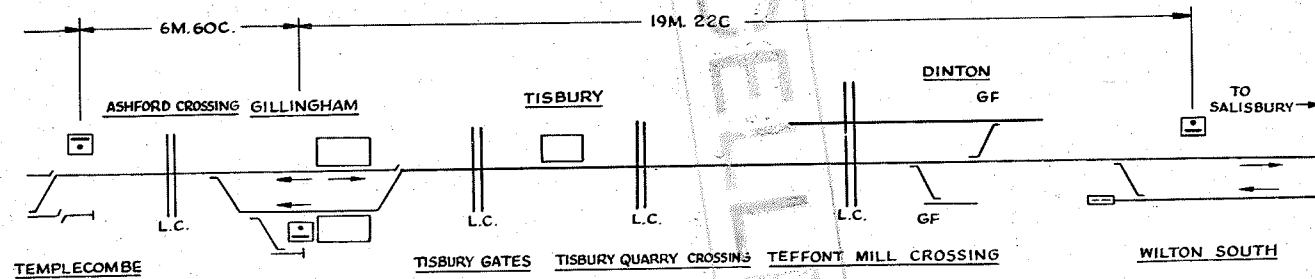
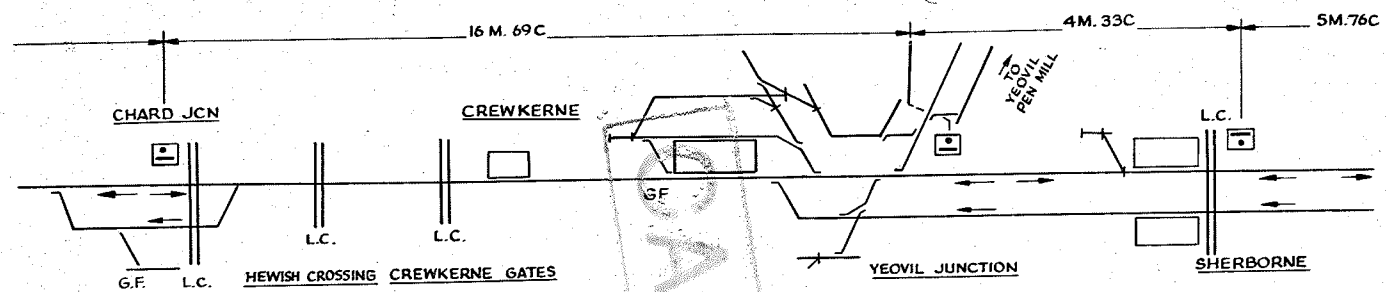
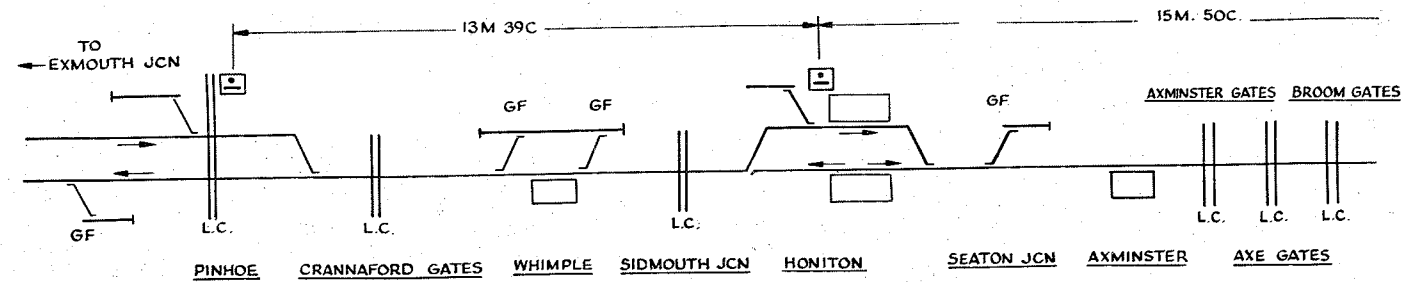

WILTON SOUTH TO PINHOE - SINGLING OF LINE

FIG. 6

B. R. STANDARD TOKENLESS BLOCK
WILTON SOUTH TO PINHOE
BLOCK WIRING - SIMPLIFIED CIRCUITS

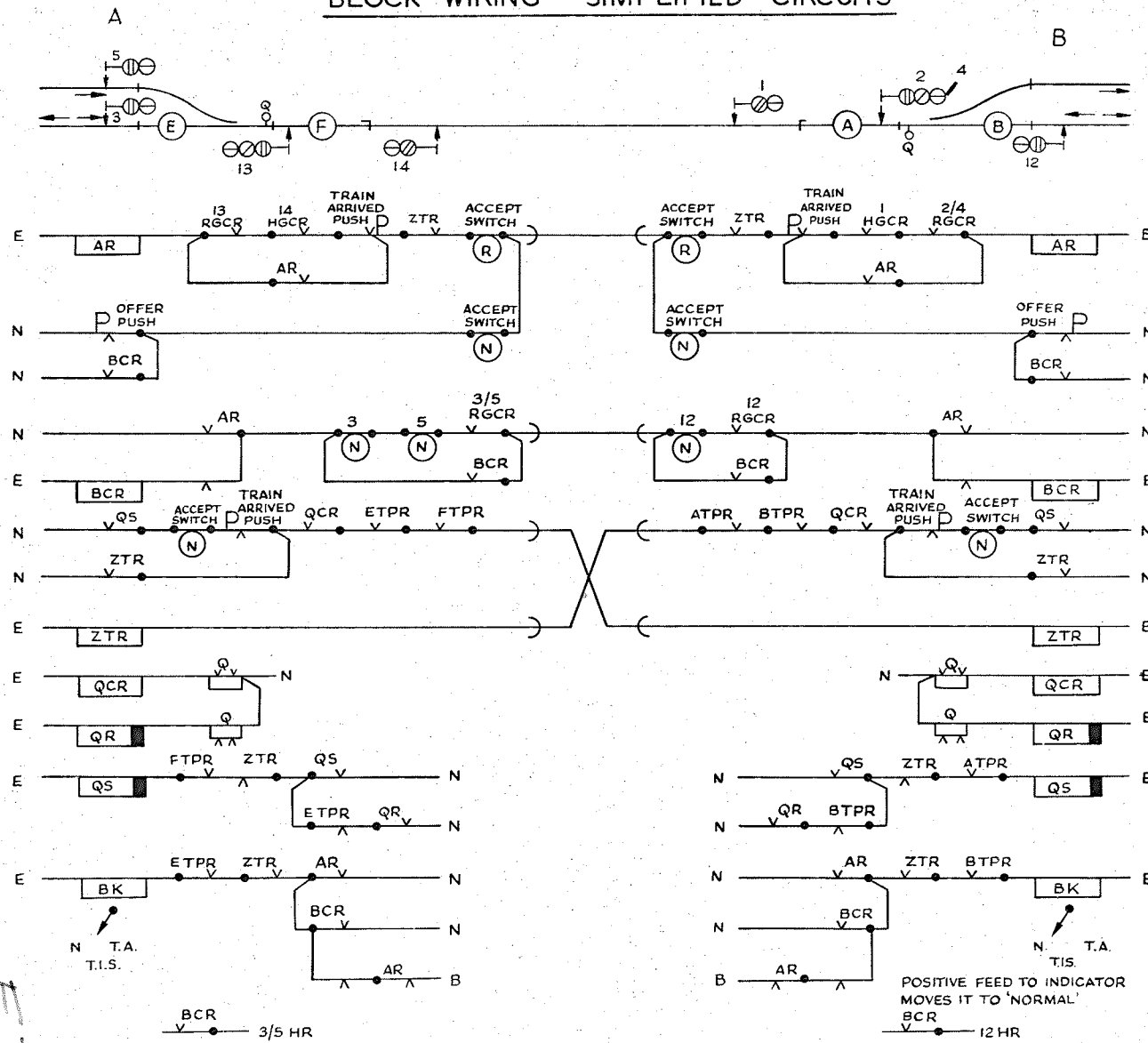
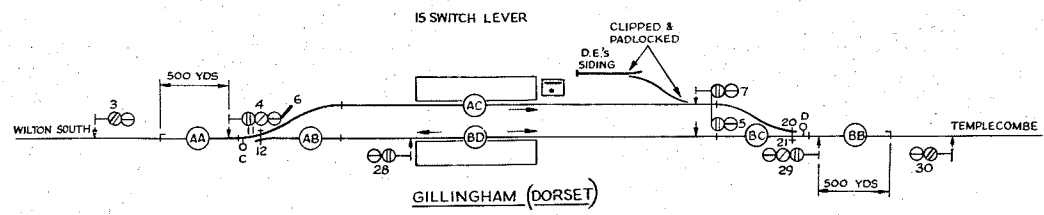

FIG. 7

14
13
12
11
10
9
8
7
6
5
4
3
2
1



NO	RELEASED BY	LOCKS	JUNC IND	ASP	REQUIRES SIGNAL AHEAD	APPROACH CONTROL		CONTROLLED BY				NORMAL LOCK RELEASED BY			BACKLOCK RELEASED BY		
						TRACK OCC.	SECS	BLOCK INDICATOR TRAIN ACCEPTED FROM	TRACKS	DETECTION	F.P.L. IN	BLOCK INDICATOR TRAIN ACCEPTED FROM	BLOCK INDICATOR LINE NORMAL FROM	TRACKS	SIGNALS ON	BLOCK INDICATOR TRAIN ACCEPTED FROM	BLOCK INDICATOR LINE NORMAL FROM
3	4, 5.			G	4 & 5 AT G												
4	11, 12.	(28, 29w 15)		Y		AA	30		AB, BD.	(12)	(11)						
				G	5 AT G												
5		20 (15 (15)) (28, 29w 15)		G													
6	11.	12.	LI	Y		AA	30		AB, AC.	12	(11)						
				G	7 AT G	AA	6										
7	20.			G													
11		(12 (12))															AB
12		6.															
15	11, 12, 21.											WILTON SOUTH & TEMPLECOMBE } OR AC WILTON SOUTH } OR AC TEMPLECOMBE } OR AC TEMPLECOMBE } MILTON SOUTH } BD OR BD	5, 7, 28.	WILTON SOUTH & TEMPLECOMBE } OR AC WILTON SOUTH & TEMPLECOMBE } OR AC WILTON SOUTH & TEMPLECOMBE } (8)			
20		5, 21.															
21		20.															BC
28	12.	(15 (15)) (4.5w 15)		G													
29	21.	(4.5w 15)		Y	28 AT R	BB	30										
				G	28 AT G				BC, BD.	20	(21)						
30	28, 29.			G	29 & 28 AT G												

CANCELLED
 F 8

BLOCK		SIGNALS ON	LEVERS	TRACKS	TRACKS/TREADLE OCCUPIED * CLEARED	PUSH BUTTON OPERATED
TO & FROM TEMPLECOMBE	TRAIN ACCEPTED	5, 7, 29, 30.	5, 7, 15.			OFFER
	TRAIN IN SECTION			(BB) or (BC)		
	LINE NORMAL			BB	BC D	TRAIN ARRIVED COMPLETE
TO & FROM WILTON SOUTH	TRAIN ACCEPTED	3, 4, 6, 28.	15, 28.			OFFER
	TRAIN IN SECTION			(AA) or (AB)		
	LINE NORMAL			AA	AB C	TRAIN ARRIVED COMPLETE

FIG 8

Gasetner

14
13
12
11
10
9
8
7
6
5
4
3
2
1